



## MT145TZ

Ageing Wine Cellar  
Prestige  
Built-in



### GENERAL INFORMATION

**Number of bottles : 143**  
**Number of zones : 3**  
**Adjustable temperature range : 5-20°C**  
**Noise level : 38dB**  
**Energy class : G**  
**Climate class : ST (16-38)**  
**Vinotag compatible : Yes**

## Product description

### BUILT-IN & FREE-STANDING

The MT145TZ has the particularity of being able to be installed free-standing or built-in. Its multi-choice installation allows it to integrate easily into your interior, whether in your living rooms or in your kitchen.

### LOW E-GLASS

The cellar door ensures optimal security, the lock protects the wine in your absence with the glazing door with low-E glass filter protects the bottles from UV and reduces the exchange of cold and heat between the interior of the cabinet and its external environment to achieve real energy savings.

### ACCOMPANY YOUR WINES AT THEIR PEAK DATE

Thanks to its 3 zones, with independent settings, age and bring to tasting temperature several types of wine in the same cellar. Aging cellar commitments, age your wines in complete safety. The MT145TZ aging cellar concentrates essential characteristics to reproduce the storage conditions of a natural cellar: constant temperature, controlled humidity, anti-vibration technology (SilentBlock), air renewal system (3 active carbon filters) and protection against the light.

### OPTIMIZED STORAGE



#### TRIPLE TEMPERATURE ZONE

Store and refresh all your wines at the correct temperature in the same cellar



#### SIDE LED LIGHT

Improves visibility of your wine selection with interior side LED lighting (top to bottom of the cellar)



#### SLIDING SHELVES

Access easily to your stored bottles thanks to telescopic rails



#### LOCK

Secure your wine collection in all time

# MT145TZ

EAN-13 - 3541362209023

## Capacity and Temperature

- **Number of bottles: 143**
  - Upper zone : 51
  - Middle zone : 40
  - Lower zone : 52
- **Adjustable temperature: 5-20°C**
  - Upper zone : 5-20°C
  - Middle zone : 5-12°C
  - Lower zone : 12-20°C

## Door

**Door color :** Stainless steel  
**Number of glass layers :** 2  
**Anti-UV :** Yes  
**Tempered glass :** Yes  
**Lock :** Yes  
**Reversible door :** No  
**Handle type :** Pulling bar

## Security

**Alarm :** Door, Temperature  
**Winter system :** No  
**Child lock :** Yes

## Logistic

**Net dimensions (WxDxH):** 59.5 x 67.5 x 176.0  
**Gross dimensions (WxDxH):** 66.0 x 77.8 x 184.8

## Technical Data

**Energy class :** G  
**Annual energy (KWh/a) :** 179  
**Climate class :** ST (16-38)  
**Noise level :** 38dB / C  
**Energy Efficiency Index :** 170.8 %  
**Power input :** 120.00 W  
**Voltage :** 220-240 V  
**Length of power cable :** 180 cm  
**Plug Type :** E type  
**Type of gas :** R600a  
**Gas charge :** 38 g  
**Type of compressor :** standard  
**Main cooling system :** Air moving system  
**Charcoal filter :** 3  
**Anti-vibration system :** Yes  
**Adjustable feet :** 4 / 0.6 cm

## Light

**Light source :** LED  
**Light color(s) :** Cold White  
**Dimmable light :** no  
**Light switch :** yes

**Qty per 20' :** 24  
**Qty per 40' :** 54  
**Qty per 40 HC :** 73  
**Customs code:** 8418501990

# MT145TZ

EAN-13 - 3541362209023

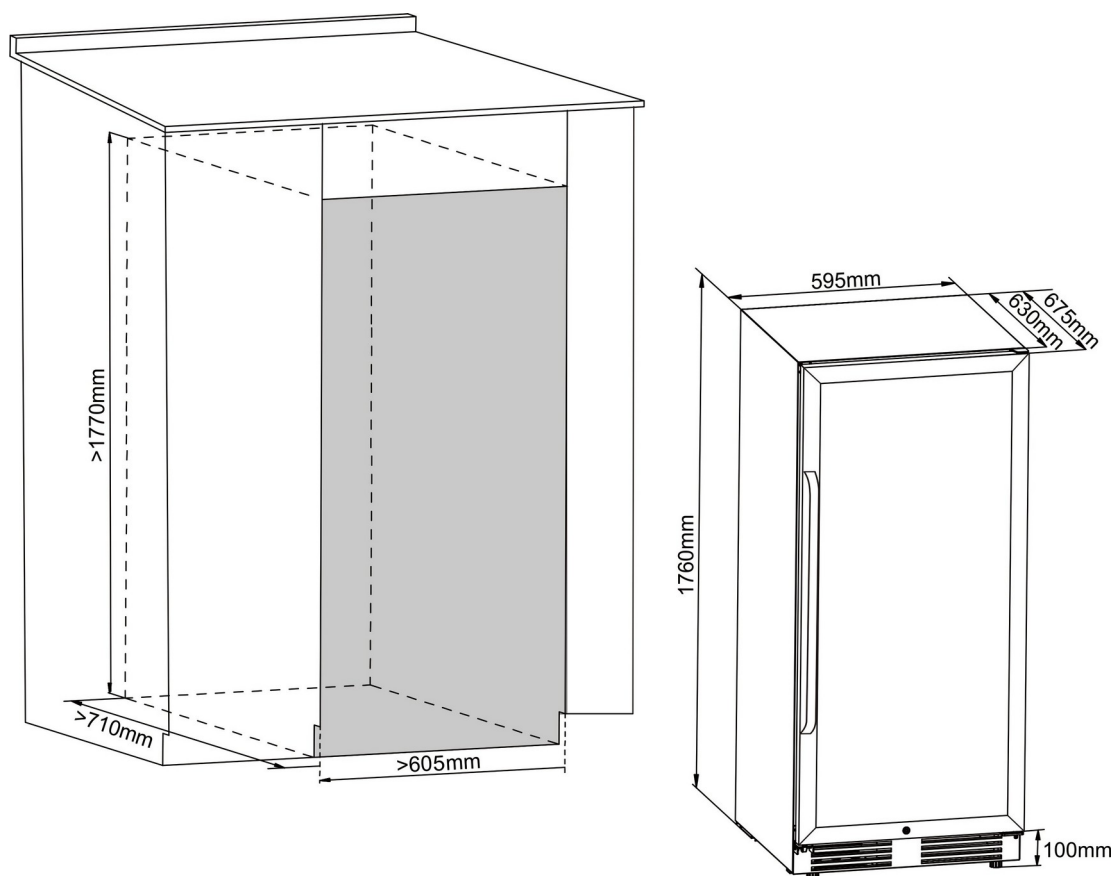

## Accessories

- 3 charcoal filters, (FILTRE3)
- 7 shelves, wooden with stainless steel front, sliding, rails

**Compatible accessories references :** PIERREDELAVE, BOITEPOURPIERRES, FILTRE3

## Built-in information

**Built-in dimensions (WxDxH) :** 60.50 x 71.00 x 177.00

**Warning installation :** This product is equipped with a front ventilation system. Follow the installation instructions to ensure proper operation of the unit.





## MT150DZ

Ageing Wine Cellar  
Prestige  
Built-in



### GENERAL INFORMATION

**Number of bottles : 152**  
**Number of zones : 2**  
**Adjustable temperature range : 5-20°C**  
**Noise level : 39dB**  
**Energy class : G**  
**Climate class : ST (16-38)**  
**Vinotag compatible : Yes**

### Product description

**BUILT-IN & FREE-STANDING :** Modern, the MT150DZ has the particularity of being able to be installed free-standing or built-in. Its multi-choice installation allows it to integrate easily into your interior, whether in your living rooms or in your kitchen.

**LOW-E GLASS :** The cellar door ensures optimal security, the lock protects the wine in your absence while the glazing door with low-E glass filter protects the bottles from UV and reduces the exchange of cold and heat between the interior of the cabinet and its external environment to achieve real energy savings.

**ACCOMPANY YOUR WINES AT THEIR PEAK DATE :** Thanks to its 2 zones, with independent settings, age and bring to tasting temperature several types of wine in the same cellar. Aging cellar commitments, age your wines in complete safety. The MT150DZ aging cellar concentrates essential characteristics to reproduce the storage conditions of a natural cellar: constant temperature, controlled humidity, anti-vibration technology (SilentBlock), air renewal system (2 active carbon filters) and protection against the light.

**OPTIMIZED STORAGE :** Store your wines on its 7 beech wood shelves with stainless steel front; ergonomic and sliding, they allow quick and easy access to your bottles. The LED interior lighting (on both sides) allows rapid identification of



#### DUAL TEMPERATURE ZONE

Store and refresh all your wines at the correct temperature in the same cellar



#### SIDE LED LIGHT

Improves visibility of your wine selection with interior side LED lighting (top to bottom of the cellar)



#### SLIDING SHELVES

Access easily to your stored bottles thanks to telescopic rails



#### INSTALLATION

Both free standing and built-in you can install your cellar at the location of your choice

# MT150DZ

EAN-13 - 3541362209016

## Capacity and Temperature

- **Number of bottles: 152**
  - Upper zone : 80
  - Lower zone : 72
- **Adjustable temperature: 5-20°C**
  - Upper zone : 5-20°C
  - Lower zone : 5-20°C

## Door

**Door color** : Stainless steel  
**Door glass color** : Grey  
**Number of glass layers** : 2  
**Anti-UV** : Yes  
**Low-e glass** : Yes  
**Tempered glass** : Yes  
**Lock** : Yes  
**Reversible door** : No  
**Handle type** : Pulling bar  
**Self-closing door** : No

## Security

**Alarm** : Door, Temperature  
**Winter system** : No  
**Child lock** : Yes

## Logistic

**Net dimensions (WxDxH)**: 59.5 x 67.5 x 176.0  
**Gross dimensions (WxDxH)**: 66.0 x 77.8 x 184.8

## Technical Data

**Energy class** : G  
**Annual energy (KWh/a)** : 181  
**Climate class** : ST (16-38)  
**Noise level** : 39dB / C  
**Energy Efficiency Index** : 171 %  
**Power input** : 120.00 W  
**Voltage** : 220-240 V  
**Length of power cable** : 180 cm  
**Plug Type** : E type  
**Type of gas** : R600a  
**Gas charge** : 39 g  
**Type of compressor** : standard  
**Main cooling system** : Air moving system  
**Charcoal filter** : 2  
**Anti-vibration system** : Yes  
**Adjustable feet** : 4 / 0.6 cm

## Light

**Light source** : LED  
**Light color(s)** : Cold White  
**Dimmable light** : no  
**Light switch** : yes

**Qtty per 20'** : 24  
**Qtty per 40'** : 54  
**Qtty per 40 HC** : 73  
**Customs code** : 8418501990

# MT150DZ

EAN-13 - 3541362209016

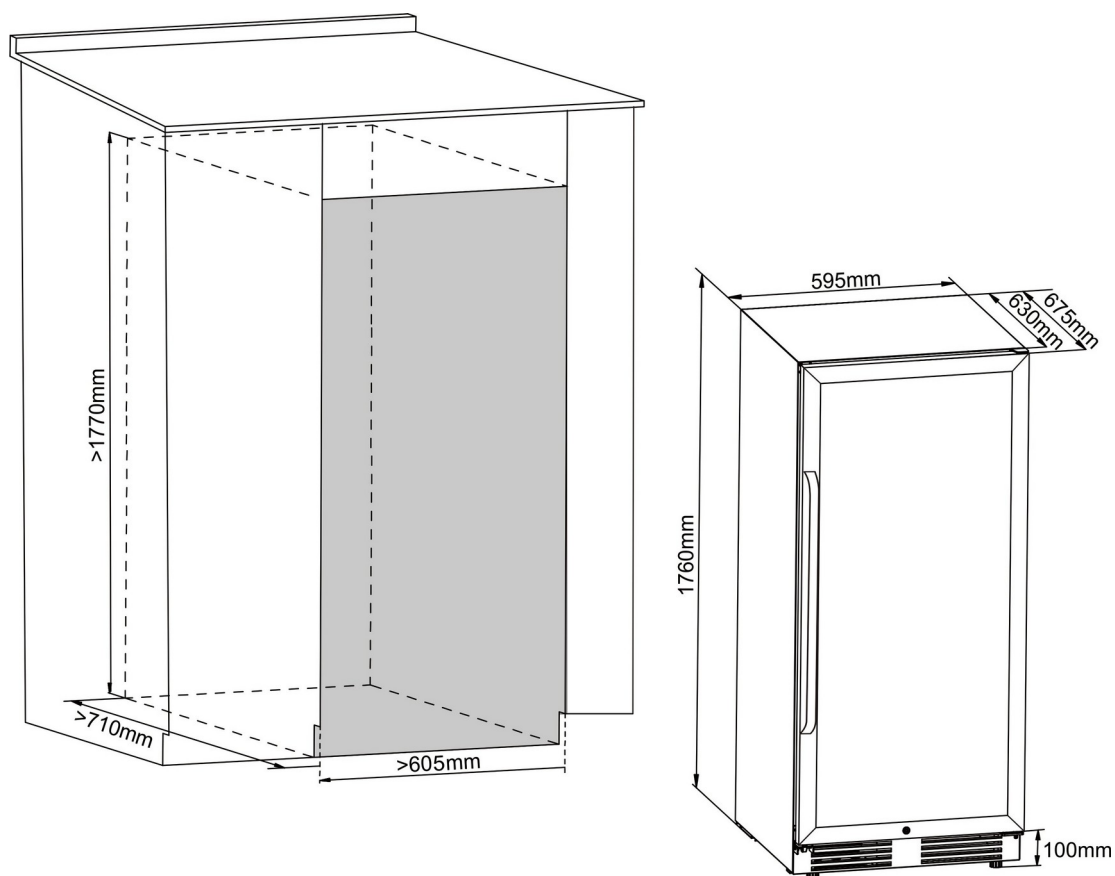

## Accessories

- 2 charcoal filters, (FILTRE3)
- 7 shelves, wooden with stainless steel front, sliding, rails

**Compatible accessories references :** PIERREDELAVE, BOITEPOURPIERRES, FILTRE3

## Built-in information

**Built-in dimensions (WxDxH) :** 60.50 x 71.00 x 177.00

**Removable plinth :** Yes

**Warning installation :** This product is equipped with a front ventilation system. Follow the installation instructions to ensure proper operation of the unit.





## MT166DP

Ageing Wine Cellar  
Prestige  
Built-in



### GENERAL INFORMATION

**Number of bottles : 172**  
**Number of zones : 2**  
**Adjustable temperature range : 5-20°C**  
**Noise level : 39dB**  
**Energy class : F**  
**Climate class : SN/ST (10-38)**  
**Vinotag compatible : Yes**

## Product description

### BUILT-IN & FREE-STANDING

The MT166DP has the particularity of being able to be installed free-standing or built-in. Its multi-choice installation allows it to integrate easily into your interior, whether in your living rooms or in your kitchen.

### LOW-E GLASS

The cellar door ensures optimal security, the 2 locks protect the wine in your absence with the glazing door with low-E glass filter protects the bottles from UV and reduces the exchange of cold and heat between the interior of the cabinet and its external environment to achieve real energy savings.

### ACCOMPANY YOUR WINES AT THEIR PEAK DATE

Thanks to its 2 zones, with independent door and settings, age and bring to tasting temperature several types of wine in the same cellar. Aging cellar commitments, age your wines in complete safety. The MT166DP aging cellar concentrates essential characteristics to reproduce the storage conditions of a natural cellar: constant temperature, controlled humidity, anti-vibration technology (SilentBlock), air renewal system (active carbon filter) and protection against the light.

### OPTIMIZED STORAGE



#### DUAL TEMPERATURE ZONE

Store and refresh all your wines at the correct temperature in the same cellar



#### SIDE LED LIGHT

Improves visibility of your wine selection with interior side LED lighting (top to bottom of the cellar)



#### LOCK

Secure your wine collection in all time



#### INSTALLATION

Both free standing and built-in you can install your cellar at the location of your choice

# MT166DP

EAN-13 - 3541362209030

## Capacity and Temperature

- **Number of bottles: 172**
  - Upper zone : 67
  - Lower zone : 105
- **Adjustable temperature: 5-20°C**
  - Upper zone : 5-20°C
  - Lower zone : 5-20°C

## Door

**Door color** : Stainless steel  
**Door glass color** : Grey  
**Number of glass layers** : 2  
**Anti-UV** : Yes  
**Low-e glass** : Yes  
**Tempered glass** : Yes  
**Lock** : Yes  
**Reversible door** : No  
**Handle type** : Pulling bar

## Security

**Alarm** : Temperature, Door  
**Winter system** : No  
**Child lock** : Yes

## Logistic

**Net dimensions (WxDxH)**: 59.8 x 68.5 x 192.5  
**Gross dimensions (WxDxH)**: 65.5 x 77.0 x 196.0

## Technical Data

**Energy class** : F  
**Annual energy (KWh/a)** : 140  
**Climate class** : SN/ST (10-38)  
**Noise level** : 39dB / C  
**Energy Efficiency Index** : 122.9 %  
**Power input** : 160.00 W  
**Voltage** : 220-240 V  
**Length of power cable** : 250 cm  
**Plug Type** : E type  
**Type of gas** : R600a  
**Gas charge** : 60 g  
**Type of compressor** : standard  
**Main cooling system** : Air moving system  
**Charcoal filter** : 1  
**Anti-vibration system** : Yes  
**Adjustable feet** : 4 / 1 cm

## Light

**Light source** : LED  
**Light color(s)** : Cold White  
**Dimmable light** : no  
**Light switch** : yes

**Qty per 20'** : 24  
**Qty per 40'** : 54  
**Qty per 40 HC**: 54  
**Customs code**: 8418501990

# MT166DP

EAN-13 - 3541362209030

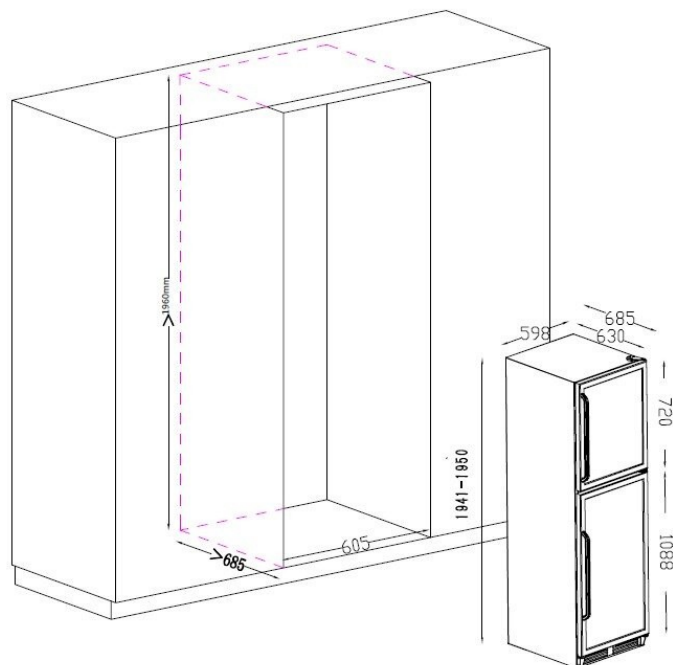

## Accessories

- 1 charcoal filter, (FILTRE4)
- 8 shelves, wooden with stainless steel front, sliding, rails

**Compatible accessories references :** PIERREDELAVE, BOITEPOURPIERRES, FILTRE4

## Built-in information

**Built-in dimensions (WxDxH) :** 605.00 x 685.00 x 1960.00

**Warning installation :** This product is equipped with a front ventilation system. Follow the installation instructions to ensure proper operation of the unit.

